



AGV5 SMART GAS CONTROL VALVE

MICROPROCESSOR-BASED FUEL CONTROL VALVE WITH POSITION AND PRESSURE FEEDBACK FOR USE WITH PLC OR OTHER CONTROLS

- Eliminates mechanical fuel valve, actuator and linkages
- Allows improved starting and speed stability
- Regulates gas flow in response to input signal
- Servo-valve with position feedback and Integrated Pressure Sensor
- Feeds back valve position and fuel manifold pressure
- Fail safe design – spring loaded closed in case of power failure
- CSA-certified for use in Class I, Divisions 1 and 2, Group D hazardous areas

The AGV5 is a single-stage, electronically-actuated, balanced poppet fuel valve designed to act as an actuation device for a supervisory (typically PLC-based) speed control system. The AGV5 can also be used as an air-fuel ratio control valve or a variable pressure regulator in a variety of applications. All valve control is derived from an industry-standard 4-20mA output signal generated by the governing controller. As a result, all governing logic, RPM and pressure setpoints, ramps, and timers are defined within the control system and are executed independently by the AGV5. Two models are available (standard and extra-large) to accommodate the fuel flow needs of engines up to 10,000 horsepower.

Use of the AGV5 makes it possible for the PLC or supervisory controller to control the gas manifold pressure when starting the engine and then switch to governing when the engine comes up to rated speed. The AGV5's internal microprocessor, pressure sensor, and position sensor allow the valve to feedback pressure and position signals to the supervisory controller for use in its control strategy. The result is that the engine will start more consistently and run in a very stable manner. The valve is also ideal for engines being automated for remote operation. The AGV5 valve, used with a supervisory controller, replaces hydraulic governors, mechanical or bladder-type fuel valves, actuators, and linkages.

The AGV5 is rugged and reliable and will operate in even the most demanding environments. It is highly dirt tolerant, since the flow-through design minimizes the effects of particulate contamination. Dirt normally found in pipeline applications passes through and does not collect in the valve. The AGV5 is also highly corrosion-resistant. There are no electrical components in the gas stream and materials exposed to the gas are corrosion resistant.

NEW!
“A-Series”
Control
Electronics



CERTIFIED
Class I, Divisions 1 and 2,
Group D

SYSTEM INTEGRATION DIAGRAM

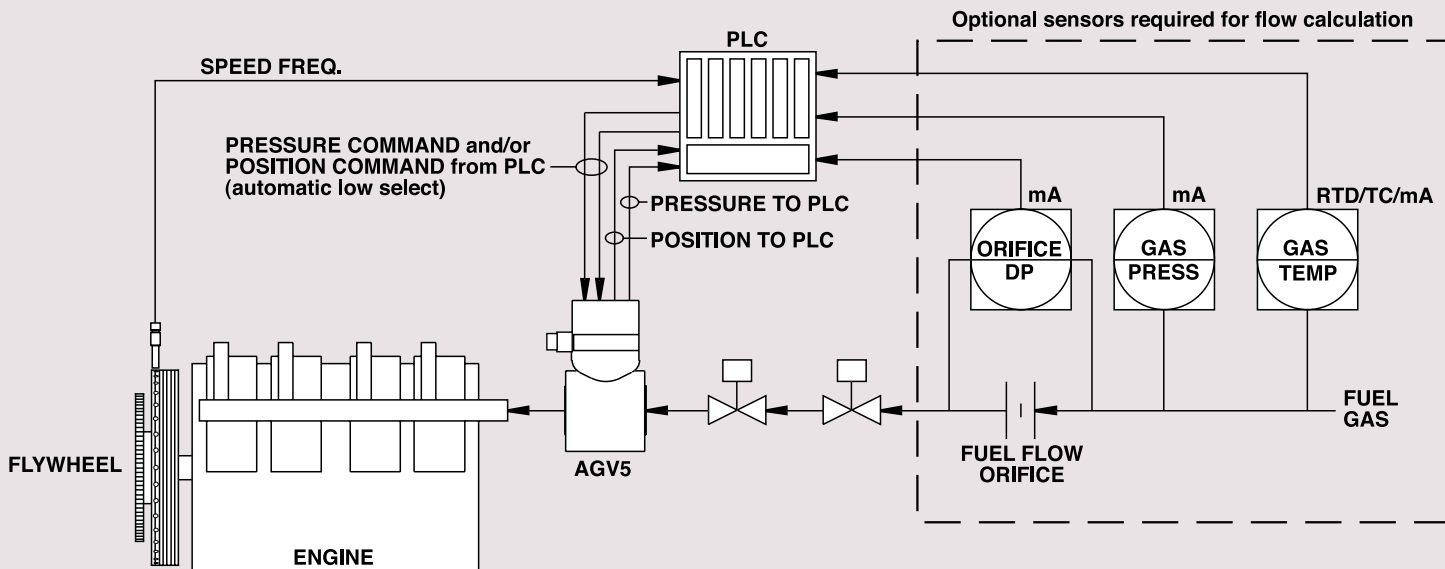

DIMENSIONS

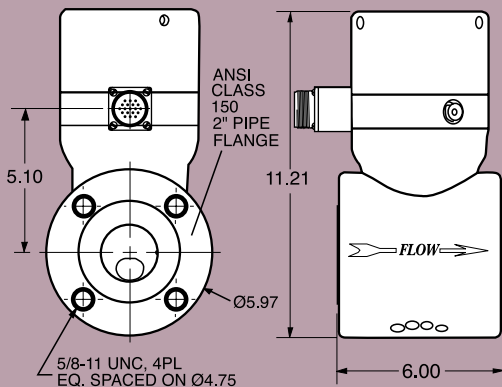

AGV5 GAS METERING VALVE, 2" CLASS 150 FLANGE

SPECIFICATIONS

INPUT SIGNALS

Analog Inputs (2 x 4-20mA signals)

Input 1 – pressure control

Input 2 – position control

OUTPUT SIGNALS

Analog Outputs (2 x 4-20mA signals)

Output 1 – position feedback

Output 2 – pressure feedback

POWER REQUIREMENTS

24Vdc, 5 Amps

TEMPERATURE

-40°F. to 185°F.

-40°C. to 85°C.

THEORY OF OPERATION

The AGV5 is a servo-valve with position feedback and a voice coil actuator. The stroke of the poppet valve is proportional to the 4-20mA input (position demand) signal. The valve has a very fast response time and will transition from open to closed in less than 40ms. The valve incorporates an embedded micro-processor, position sensor, and downstream (engine gas manifold) pressure sensor. The valve can be used in a pressure control mode or a position control mode, and can low select between the two control signals.

It is spring-loaded, incorporates a soft seat, and fails closed. It has two 4-20mA outputs (downstream pressure and actuator position).

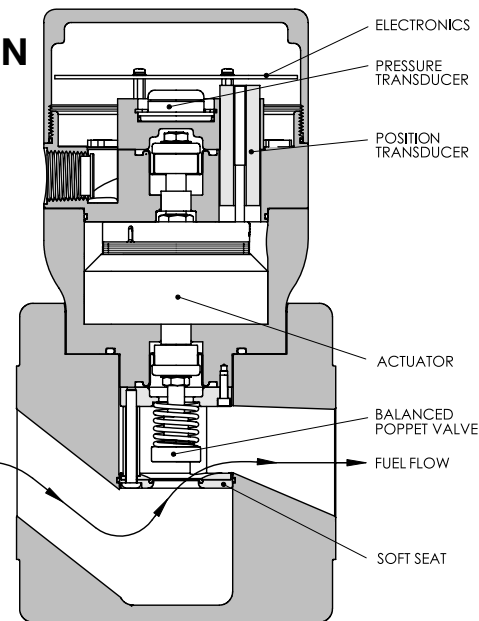

TO ORDER

VALVE

Engines up to 3,500 HP..... AGV5-1A

Engines 3,500 to 10,000 HP..... AGV5-2A

OPTIONAL ITEMS

Board Assembly Update Kit..... 881002-KT*

MS Connector Adapter 893004

Harness, 48" (MS connector option)..... 293023-16

Harness, 84" (MS connector option)..... 293026-16

Harness, 96" (MS connector option)..... 293028-16

Harness, 144" (MS connector option)..... 293027-16

* This item is used to update an older AGV5 using original electronics.

altronic[®]
inc.

712 TRUMBULL AVE / GIRARD, OH 44420
(330) 545-9768 / Fax: (330) 545-9005
www.altronicinc.com E-mail: sales@altronicinc.com
FORM AGV5 8-03 ©2003 Altronic, Inc.