

ALTRONIC®, INC.
712 TRUMBULL AVENUE
GIRARD, OHIO 44420

DIGITAL PRESSURE SWITCH & GAUGE

INSTALLATION INSTRUCTIONS DPHL01 II 2-87

WARNING: Read these instructions carefully before installing or operating the DPHL device.

DEVIATION FROM THESE INSTALLATION INSTRUCTIONS MAY LEAD TO IMPROPER OPERATION OF THE MONITORED MACHINE WHICH COULD CAUSE PERSONAL INJURY TO OPERATORS OR OTHER NEARBY PERSONNEL.

1.0 DESCRIPTION

- 1.1 The Altronic DPHL-1501 digital pressure switch & gauge is an electronic instrument designed to monitor pressure at a single point. The LCD display gives a continuous readout of the monitored pressure in pounds per square inch (psi). In addition, the monitored pressure is continuously compared against the low and high limit setpoints set by the operator from the front of the instrument. There is an output switch for each function; if the monitored pressure falls outside the established low and high limits, the appropriate output switch is activated to ground. Setpoint values are retained indefinitely thus duplicating the operation of a conventional mechanical switch. Operating power is from capacitor-discharge ignition systems (DPHL-1501) or 12-24 VDC (DPHL-1501D).
- 1.2 For proper operation, the following installation instructions must be adhered to strictly.

2.0 MOUNTING

- 2.1 Mount the pressure switch & gauge inside a control panel or to a suitable flat surface so that the display is at a convenient viewing height. This device fits the industry standard cutout for a round 4-1/2" diameter gauge. Be sure the enclosure door does not hit the push buttons.

NOTE: Avoid mounting with the LCD display facing direct sunlight. The display temperature range is -40°F. to +175°F. The pressure switches function over a range of -40°F. to +185°F.

- 2.2 The pressure input is connected to the back of the device to a 1/8"-27 fitting. Although the input signal is electronically filtered, it is recommended that an external pressure snubber be used where pulsating pressures are encountered. Pressures higher than the indicated range may cause permanent damage to the device.

3.0 WIRING (SEE WIRING DIAGRAMS)

3.1 POWER WIRING

- A. IGNITION POWERED TYPE - Connect the ignition shutdown lead (100-400V) to the IGN terminal as shown in the Wiring Diagrams. The GND terminal is connected to panel ground which should be the same as engine ground. DO NOT ground this device directly to the ignition system common coil ground.
- B. 12-24 VDC POWERED TYPE - Connect the DC power to the VDC terminals observing the proper polarity as indicated on the back of the device. NOTE: Contact the factory for specific application information if the power input to the device is from a positive ground system.

3.2 HIGH/LOW PRESSURE SWITCH WIRING - A pressure condition under the low setpoint or above the high setpoint actuates one of two normally open, solid state switches to ground in the device; these are accessible through the LO and HI terminals (+) on the back of the device. The solid state switches used have an open circuit breakdown voltage rating of 400 volts DC. The LO output switch will trip if the monitored pressure drops below the low setpoint value. The HI output switch will trip if the monitored pressure rises above the high setpoint value. If one or both pressure switches will not be used, leave the LO and/or HI terminals disconnected.

3.3 HAZARDOUS AREA OPERATION - The DPHL device operates with non-incendive circuits and can be operated with suitable precautions in Class I, Group D areas.

- A. CLASS I, GROUP D, DIVISION 2 - The DPHL device mounted in a suitable panel meets the requirements for Class I, Group D, Division 2 areas.
- B. CLASS I, GROUP D, DIVISION 1 - Ignition powered DPHL devices may be operated as intrinsically safe if the following associated devices are used:
 1. Altronic barrier 690 107 or 690 108; follow hook-up instructions supplied with barrier.
 2. Altronic DA annunciator system; connect output terminals of the DPHL device to the sensor inputs of the DA system.

4.0 OPERATION

4.1 PRESSURE READOUT - The device must be supplied from a suitable power source wired in accordance with the attached Wiring Diagrams. The measured pressure is displayed continuously on the LCD display as long as power is supplied to the device.

4.2 SETPOINT ADJUSTMENT - The low and high pressure limit setpoints are read by holding the respective PUSH TO READ button depressed; the low and high setpoints must be adjusted individually, one at a time. To adjust the setting, keep the PUSH TO READ button depressed and use a small screwdriver to turn the adjustment until the display readout matches the desired pressure. Rotating the adjustment clockwise (CW) increases the setpoint. The setpoint range is from virtually 0 to full scale. The setpoint values are retained indefinitely until altered.

GENERAL HOOK-UP DPHL-1501, DPHL-1501D

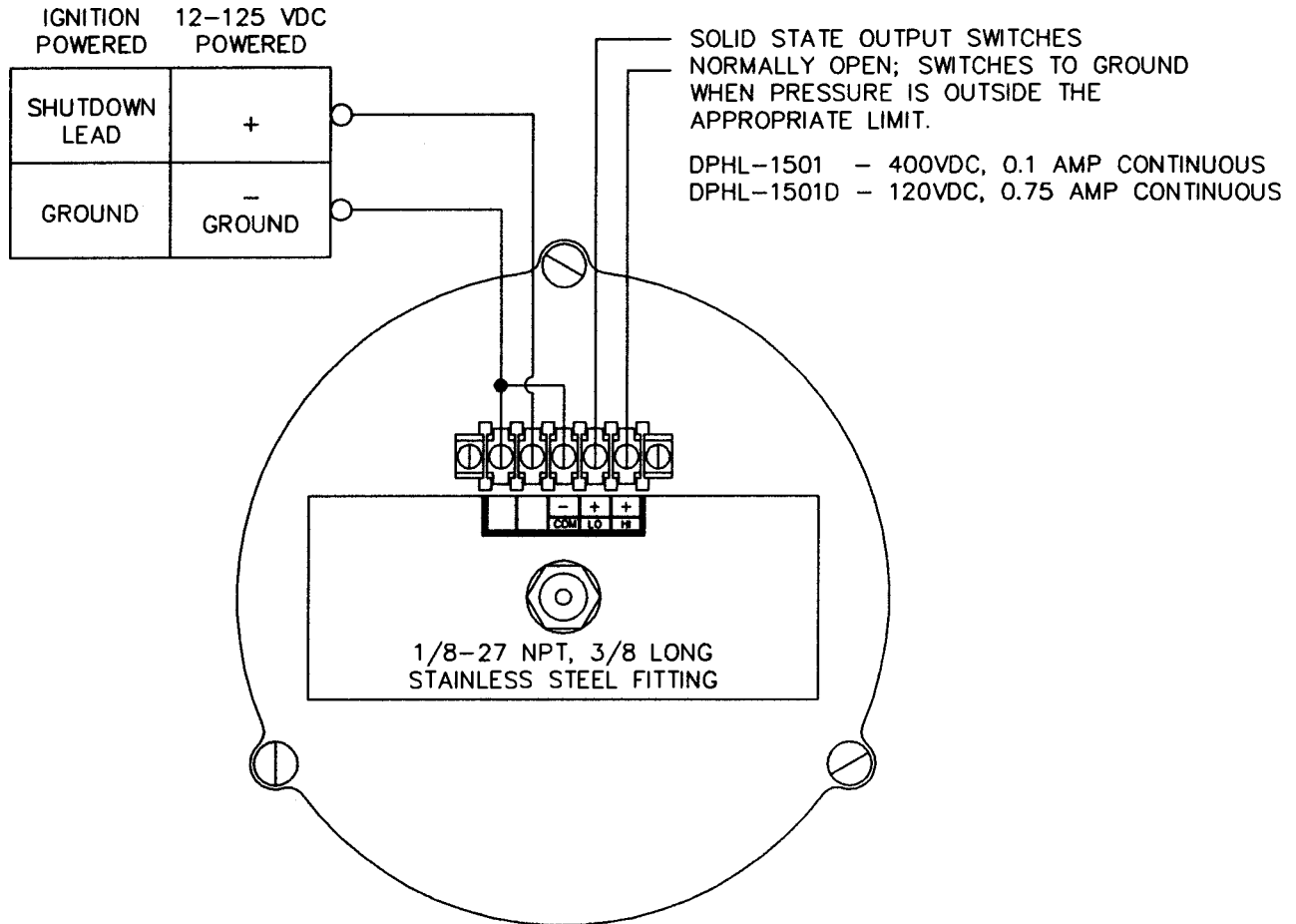

NOTE: A PRESSURE SNUBBER SHOULD BE USED WHEN MEASURING PULSATING PRESSURES. PRESSURES IN EXCESS OF THE INDICATED RANGE MAY PERMANENTLY DAMAGE THE DEVICE.

WIRING DIAGRAM - DPHL-1501 (IGNITION POWERED)

WITH ALTRONIC ANNUNCIATOR
C.D. IGNITION POWERED

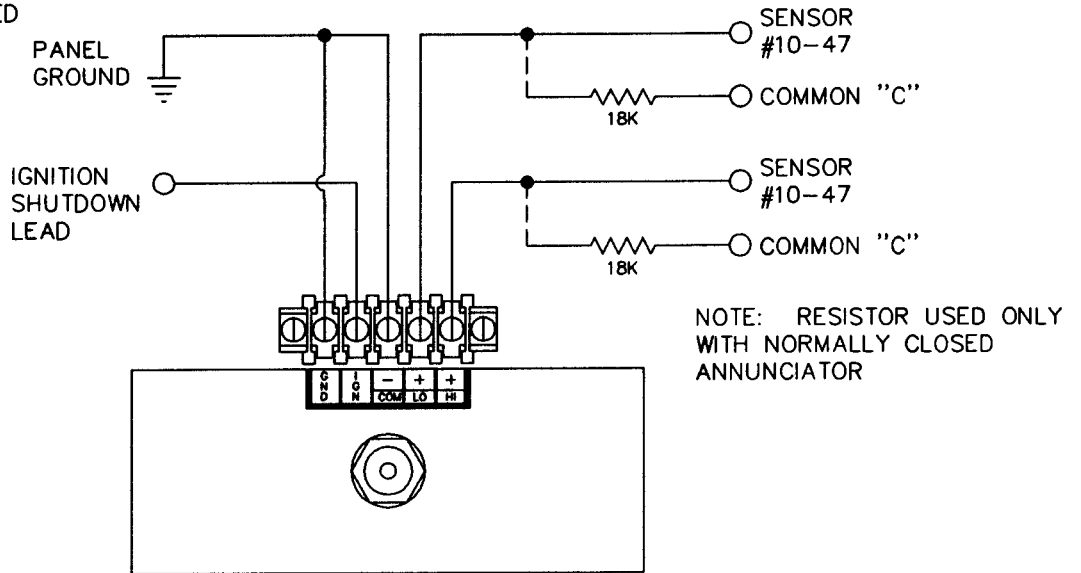

WITH MURPHY TATTLETALE
OR PNEUMATIC VALVE
C.D. IGNITION POWERED - NEG. GROUND

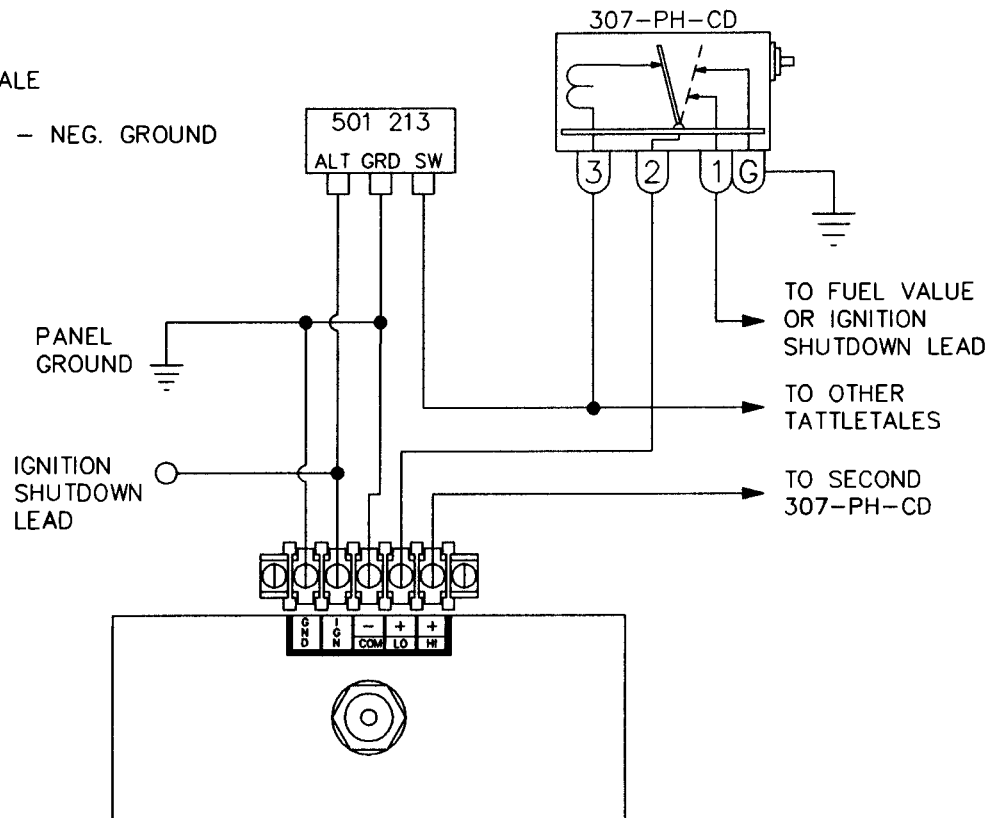

WIRING DIAGRAMS - DPHL-1501D (DC-POWERED)

WITH ALTRONIC ANNUNCIATOR
DC-POWERED

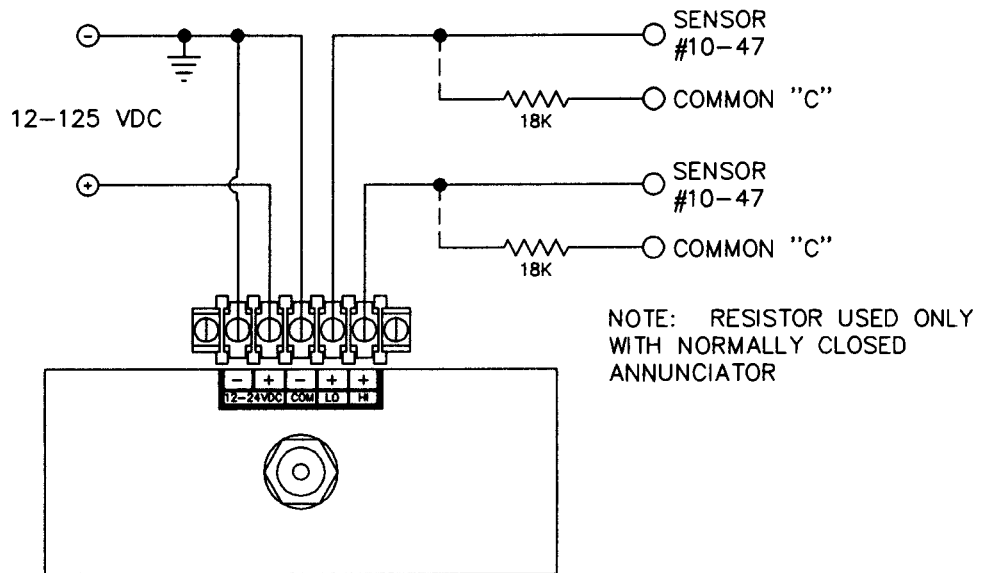

WITH MURPHY TATTLETALE
DC-POWERED

